

Model: C2F

Application

K-TOP Dismantling Joint is suitable for joining 2 pipes/ fittings with both flanged ends and easily install. Providing greater versatility for the early planning stage and the final installation stage and to allow simple maintenance works. Longitudinal adjustment facilitates installation and removal of flanged unit.

Technical Specification

Nominal Size: DN80 ~ DN600
 Max. Working Pressure: PN16
 Coating: Fusion Bonded Epoxy (min. 250µm)
 Flange Connection: BS EN 1092-2

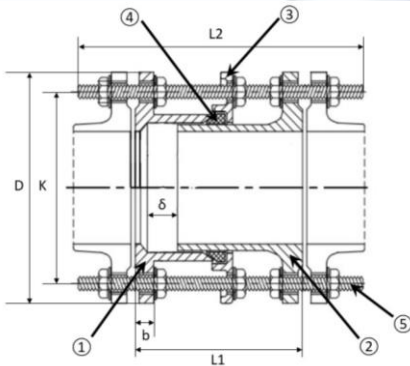

#	Description	Material
1	Fixed Body	Ductile Iron
2	Sliding Body	Ductile Iron
3	Gland	Ductile Iron
4	Gasket	EPDM
5	Fixing	Carbon Steel / Stainless Steel

Dimensions (DN80 – 600)

Size	D	K	Bolt hole	b	L1 max	δ	Fixing Bolt L2
DN 80	200	160	8 x Ø19	19	220	40	8 x M16 x 330
DN 100	220	180	8 x Ø19	19	220	40	8 x M16 x 330
DN 150	285	240	8 x Ø23	19	220	40	8 x M20 x 340
DN 200	340	295	12 x Ø23	20	220	40	12 x M20 x 360
DN 250	400	355	12 x Ø28	22	220	40	12 x M24 x 370
DN 300	455	410	12 x Ø28	24.5	220	40	12 x M24 x 400
DN 350	520	470	16 x Ø28	26.5	245	50	16 x M24 x 420
DN 400	580	525	16 x Ø31	28	245	50	16 x M27 x 440
DN 450	640	585	20 x Ø31	30	245	50	20 x M27 x 440
DN 500	715	650	20 x Ø34	31.5	245	50	20 x M30 x 460
DN 600	840	770	20 x Ø37	36	260	50	20 x M33 x 490

For larger DN, please contact with us



香港 灣仔 謝菲道90號 豫港大廈5樓

5/F Henan Building, 90 Jaffe Road, Wanchai, Hong Kong

Tel: +852 2528 0999 Fax: +852 2528 3113 Email: info@kembla.com.hk Website: www.kembla.com.hk